

# S·A·V news

FOCUS ON THE MODULAR APPROACH



Lars Fabricius\* highlights a new family of modular solutions that promises to revolutionise the approach to our building services systems

## MASTERS OF INNER SPACE

"A house," said Le Corbusier, "is a machine for living in." I'm certain that the great French architect would also have avowed that a commercial building was a machine for working in.

The problem with machines that house people is - how do you create enough room for the occupants and the working parts? How does one strike the right balance between the needs of those who work in the building and the equipment that keeps it functioning?

Here lies a paradox. In the 21st Century the working parts of those other essential machines - our cars - have become much less obtrusive, while our buildings are a virtual battleground of technology.

When did you last look under the bonnet? Could you even identify all the components there? Carmakers have opted for sealed modules, designed for

plug and play operation and just as easily unplugged for replacement - not tinkered with in the garage or at the side of the road. Reliability has improved dramatically.

A modern building is a very different story - just think of a house during the installation on an underfloor heating system to see why.

Le Corbusier had to contend with only a few pipes and a few (very few) wires. He could concentrate on the lines of his buildings, on the light and space within them.

Technology has moved on, but techniques remain much as they were in his day.

### Fight for space

Ductwork, rigid pipes, valves, controls and cables (miles and miles of them) all fight for space within the building.

Specialist installers vie for their time and place on site - working around (and often over and under) each other to get the job done on schedule. Later, commissioning engineers must try to bring order and harmony out of chaos and discord. Not an enviable task and one that sometimes proves impossible to achieve in detail.

The solution lies not just in the components of the system (we use only the best pipes and the best valves, of course) but how it is organised. Systems and sub systems can now be designed just like the modules in a car engine - built and tested off site, ready for fast, easy fixing in the minimum space.

SAV Valve Modules are specialists in the supply of

tailor-made, packaged commissioning and control centres for building services. Whether it's hot and cold water, radiators, underfloor heating, or air conditioning SAV can provide a compact, modular solution to the current battle for control of time and space.

## BOX CLEVER

All the key components of a distribution system for 2-6 Fan Coil Units, with a combined maximum output of 46kW heating or 25kW cooling, including multi-port manifold, manual air vent and isolation valves can now be housed in a pre-insulated galvanised steel SAV "box".

This "box" - no bigger than a standard fan coil unit - can be easily and quickly located



in the ceiling or floor void. Insulating the casing means there's no need to attempt vapour sealing of individual components - seals that are virtually impossible to achieve and must be broken the first time access is required!

Connections from the Module to the individual terminal units are made using a modern, flexible polyethylene-coated aluminium pipe. Other key system components including large, fine-mesh strainer, pressure test points and specially designed commissioning valves can be accommodated inside, or outside the box.

### Modules are real TEAM players



- **Architect:** less risk of damage to expensive finishes.
- **Consultant:** easier to achieve modular control with good valve authority.
- **Contractor:** easier to install and commission.
- **Facilities Manager:** easier to maintain and a flexible friend if the system is reconfigured.

\* The author is Managing Director of SAV

# Heating and hot water in E

**S**AV Valve Modules has supplied a complete package of engineered solutions for one of Europe's "greenest" buildings.

Working closely with contractors N. G. Bailey SAV's technical team developed a pre-assembled control centre for the plumbing heating and potable water services, based on the company's well-proven Commissioning Module technology.

The new Multi Services Module system offers considerable advantages according to SAV Sales Director Jan Hansen.

"At long last there's no need to plumb out complete individual and heating systems for individual domestic systems in apartment blocks like the Green Building".

The SAV Multi Services Modules were engineered off-site and supplied custom-tailored to the project and the individual areas complete with all the manifolds and controls needed for domestic services and underfloor heating.

Like many projects where energy saving is king, the Green Building utilises variable flow water systems. Where necessary we



built in Differential Pressure Control Valves (DPCV's) to create "mini" systems that overcome high shut off pressures and poor control authority at a fraction of the cost of the "macro" approach.

Integral energy meters make it possible to accurately monitor energy consumption of individual units throughout the building.

## Leading edge

The Green Building represents the leading edge of environmentally-friendly technology, creating a "mixed" residential/educational and commercial development that is ideal for its inner city location.

Set in Macintosh Village, on the south side of Manchester City Centre, the Green Building features a ten storey inner "drum" with 32 one and two-bedroom apartments. The design by Terry Farrell and Partners also provides for a 120-place pre-school nursery, a doctors' surgery and three floors of commercial accommodation.

Building services have been designed for minimum energy consumption. Solar panels on the 11th floor plant level provide up to 40% of the hot water required for the underfloor heating systems and domestic hot water supplies. A wind turbine also located on the roof contributes to the electricity supply.

## SIDE BY SIDE SOLUTION

**L**ocation isn't only important to estate agents. Facilities Managers need flexibility in being able to locate equipment for best routing of flow and return lines and best use of available space.

Nowhere is this more important than in hotels where services must often be located in a riser – to save room space and to provide easy external access without disturbance to occupants for maintenance or repair.

SAV Commissioning Modules offer all the versatility that's required. Units can be assembled in "stick" configuration for

location in the ceiling void, or as "compacts" for mounting in risers. The latter can be configured for horizontal operation with each Commissioning Module controlling flow and return to fan coils on either side of the riser.

In all cases valves, manifolds and strainers are mounted in such away as to give easy access to all components and pipe connections.

Both versions can be pre-assembled prior to delivery. Insulated boxes are available for all SAV Commissioning Modules.



# Europe's Greenest Building

The "drum" at the inner core of the Green Building is clad in cool green, recyclable insulation material. Even its circular shape makes an energy saving contribution by minimising the surface area available to lose heat.

The Green Building is predicted to achieve an Eco Homes rating of 144.

## Pre-assembled

The space-saving SAV Plumbing Modules - with all components pre-assembled on a steel back plate - were wall-mounted in discreet locations as a first fix, with the simple flow and return connections made later when water is ready to flow. As the Green Building entered its final phase, plumbing and heating services were balanced and commissioned from the Multi Services Module. The latter also serves as a secure control and isolation centre to simplify maintenance and repair throughout the life of the system.

Safe, space and energy saving underfloor heating has been used in all the key areas of the Green Building - including the apartments and the nursery. SAV supplied all the system components including the pipework and manifolds, which are built into the Multi Services Modules. Special SAV features include incorporation of a Shunt Pump/Temperature Control Group with a fail-safe feature in the form of a mechanical bypass damper into each Module. This makes it physically impossible for high temperature water to be diverted into the UFH circuit loops.

The Multi Services Modules also feature SAV's Alpha-Basis modular interface complete with pump control module. Each apartment has its own Alpha-Basis unit controlling two independent heating zones i.e. living area and bedroom/bathroom each with its own thermostat.

Alpha-Basis is designed to ease the control wiring of underfloor heating by creating a single connection centre for all



control functions. Modular design makes it possible to build up a unit, which is matched perfectly to the particular application.

Not even a screwdriver is required, quick clamps are used for all wiring

connections and every phase of the connection programme can be monitored

The Green Building is a Taylor Woodrow Capital Developments project. Building services were designed by TEL and installed by N.G.Bailey.

## FLUSHED WITH SUCCESS!

**T**he system incorporates all the components needed to flush, vent and balance the fan coils. The time consuming business of "looping out" is consigned to history. Forward and back flushing can be easily achieved from the commissioning module for individual heating/cooling lines. Flow of LTHW and chilled water can be easily balanced by a single operative - it's a cost-effective alternative to the hard pressed teams of men with ladders and walkie talkie's that have been a feature of system commissioning until now!

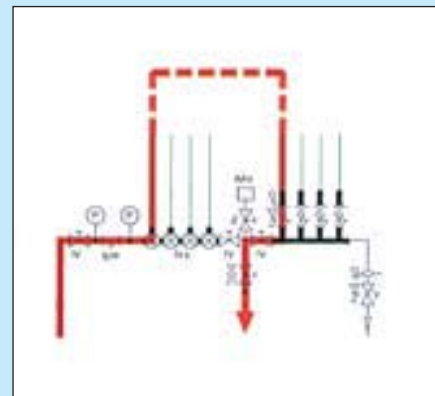
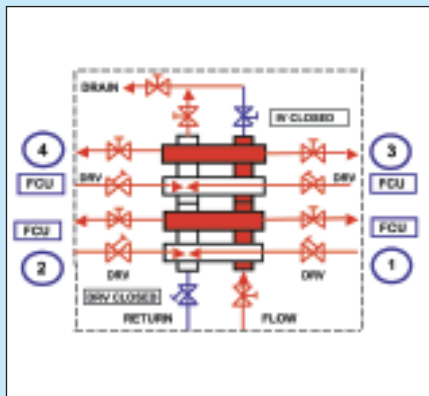

# FAQ's

## The answers to some of the points you raise

**Q:** How are Commissioning Modules "energy saving"?

**A:** By varying the speed of the pump to match system demand, energy consumption can be significantly reduced. Estimated pump energy savings of between 60-70% have been predicted for typical building heating and cooling applications.

However, designers have to employ variable speed pumps, without excessive expenditure elsewhere in the system - and without risking embarrassing operating problems.

The Differential Pressure Control Valve (DPCV) offers a solution by compensating for variations in the total branch pressure caused by the movement of control valves, or variations in pump speed.

By using SAV Commissioning Modules groups of terminal units can share facilities.

**Q:** How do we size pipes and manifolds and calculate pressure drops?

**A:** You don't have to. SAV Valves Systems has developed special software to support the range of Commissioning Modules.

**Q:** Is main branch balancing required?

**A:** No. ALL balancing can be carried out from the Commissioning Module.

## IT'S A HEATING AND COOLING BEAM SOLUTION FOR BSKYB

**S**AV Commissioning Modules are playing a key role in the environmental control systems currently being installed at the headquarters of one of the UK's major television networks.

The BSKyB facility at Brentford in West London is being completely refurbished with all three buildings on the site refitted with new services systems and complete new internal layouts and fittings.

Building 1 is a four-storey unit, while Buildings 2 and 3 offer three-storey accommodation. All floors will be served by a dual-coil heating and cooling beams integrated into the ceilings and linked to packaged chillers and boilers located in plant rooms serving each building.

For control purposes each BSKyB building is divided into 7.5 metre zones, each typically being equipped with 3 dual-coil beams linked by Haka flexible multi-layer pipework to a dedicated SAV Commissioning Module. Modulating pumps supply heating and cooling water to the beams via Differential Pressure Control Valves (DPCV's) built in to each SAV Module. This ensures good local



SAV Commissioning Modules provide a discreet distribution solution for the dual-coil heating and cooling beams at BSKyB.

control with minimum noise and excellent valve authority.

Temperature conditions are controlled by the a BMS thermostat in each zone linked to the 2-port actuators on the flow from the SAV Module and the double regulating valve on the return. SAV Commissioning Modules incorporate the new Cimberio Double Regulating Valve. Balancing of the system flow rates is much easier to achieve - operation of the handle raising or lowering the vertical indicator, so the setting can be read from any angle.

Mechanical engineering services for the BSKyB project are provided by Meica Services Ltd

## ActionFile The Modular Approach In Action

SAV Commissioning Modules are already being specified for application in projects all over the United Kingdom.

Building services designers for major developments including Harvey Nichols Manchester store, the Albion Riverside apartments and the new Stock Exchange building are adopting the modular approach.

Centralised balancing and commissioning valves makes it easier and quicker to commission each fan coil group.



Patent Application No. 01 13234.9

### For further information contact:

SAV VALVE MODULES, SCANDIA HOUSE, 131 ARMFIELD CLOSE,  
WEST MOLESEY, SURREY KT8 2JR

TEL: +44 (0)20 8941 4153 FAX: +44 (0)20 8783 1132

WEB: [www.savmodules.com](http://www.savmodules.com) E-MAIL: [info@savmodules.com](mailto:info@savmodules.com)

**S·A·V**  
VALVE MODULES